



RU2 Systems, Inc.

Radar Speed Display Signs Manufacturing & Sales

RU2 Fast-3000

VMS Radar Speed Display Trailer



The RU2 Fast-3000 Series Speed Display Trailer has a full graphic, medium density LED array capable for 1 to 4 lines of text, full graphic characters and complex animation. The VMS display sign folds down creating a lower trailer profile for easy transport and storage. Standard features include high speed blanking, flashing digit violator alert and traffic management arrows, the standard FHWA approved VMS message library and customization software for both text and animation.

Optional features include solar power assist, digital video photo enforcement system and, our RU2 Systems Data Acquisition Package, which records the time, date and speed of oncoming vehicles without the use of cumbersome pneumatic tubes placed across the street!

RU2 Systems: The Industry Leader in Speed Display Technology

4840 East Jasmine Street, Suite 102, Mesa, AZ 85205

[P] 480-982-2107 [F] 480-982-5237

Toll Free 877-982-2107

e-mail: info@ru2systems.com www.ru2systems.com

Fast-3000



RU2 Fast-3000

VMS Radar Speed Display Trailer

Standard Features:

- Single directional K-band radar unit
- Up to 50" Amber AllnGaP LED display characters
- Display protected by 3/16" GE Lexan® with a smoked, non-glare finish
- Automatic intensity adjustment to ambient light conditions
- 18" x 24" MUTCD R2-1 speed sign / 5-65 MPH overlays
- Keyed On/Off switch
- Four (4) AGM aviation grade batteries (368 A/Hrs total)
- Single cycle 24 hour ON/OFF clock
- Full FHWA approved VMS library
- Flashing Digit Violator Alert
- Directional Traffic Arrow Patterns
- Minimum Display Speed / High Speed Cut-off
- Unit defaults to last settings upon power up

Options Available:

- Solar power – 65 - 110 W panel
- Data acquisition packages for counting and clocking oncoming vehicles
- Remote data transmission
- Alarm system
- Locking lugs
- Trailer cover

Construction:

- 3" 10 Gage steel channel frame
- Polyester powder coat finish over high zinc epoxy primer
- (3) Stabilizer jacks with a 750 lb capacity each
- 4.80 x 13 ST tires on 5 lug automotive type hubs
- 2" Class II ball coupler
- Full 7" wide, 14 gauge steel fenders
- 2000 lb rated axle
- Leaf spring suspension
- Taper roller bearings
- Curb Weight: 680 lbs (est)



42"
Transport Mode

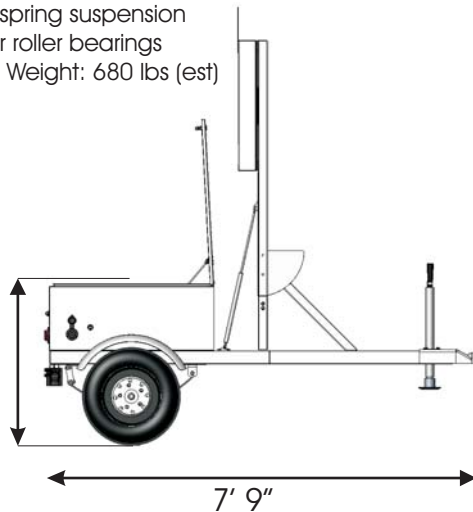

8' 9"

5' 2"

WARRANTY:

RU2 Systems warrants their LED Displays and this Trailer for Two Years. The Radar Gun is warranted for Two years. On-site labor is not included. However, parts are repaired within five business days of receipt, and include ground-shipping expenses. Warranty does not include physical damage from misuse or vandalism.

RU2 Systems, Inc.
4840 E. Jasmine St., Suite 102
Mesa, AZ 85205

[P] 480-982-2107 [F] 480-982-5237
Toll Free 877-982-2107
www.ru2systems.com