



# RU2 Systems, Inc.

Radars Speed Display Signs Manufacturing & Sales

## RU2 Fast 1000

### Radars Speed Display Trailer



The RU2 Fast 1000 Radar Speed Display Trailer is a heavy duty product ideal for use on highways and streets where speeding is a problem. The 18" tall full matrix characters are created with high intensity LED's which adjust their brightness to the ambient light conditions for maximum viewing day or night. The display is protected with GE Lexan<sup>®</sup> shielding and the trailer is powder coated top to bottom. All hardware is stainless steel, including theft deterrent screws for the speed limit and "Your Speed" signs.

Custom built with top quality, many optional features may be added, including data recording, electric leveling jacks and our violator alert lights. A solar panel is standard equipment for this model trailer.

**RU2 Systems: The Leader in Speed Display Technology**

4840 East Jasmine Street, Suite 102, Mesa, AZ 85205

[P] 480-982-2107 [F] 480-982-5237

Toll Free 877-982-2107

e-mail: [info@ru2systems.com](mailto:info@ru2systems.com) [www.ru2systems.com](http://www.ru2systems.com)

RU2 Fast 1000



# RU2 Fast 1000

## Radar Speed Display Trailer

### Standard Features:

- Single directional K-band radar unit
- 18" Amber AllnGaP LED display characters
- Display protected by 3/16" GE Lexan® with a smoked, non-glare finish
- Solar power – 40-watt panel
- Automatic intensity adjustment to ambient light conditions
- Swivel-head Display rotates 90 degrees in each direction for optimum viewing angle. Locks in place for travel.
- Keyed On/Off switch
- Two (2) AGM aviation grade batteries
- Single cycle ON/OFF clock
- Flashing Digit Violator Alert
- Directional Traffic Arrow Patterns
- Minimum Display Speed / High Speed Cut-off
- Unit defaults to last settings upon power up

### Options Available:

- Data acquisition packages for counting and clocking oncoming vehicles
- Violator Alerts: Flashing Red and Blue LED's and/or "SLOW DOWN" message in Red LED's and/or White Strobe
- Alarm system
- Electric Leveling Jacks
- Removable Trailer Tongue
- Trailer cover

### Construction:

- 2" square steel tubing frame
- 1/8" steel diamond plate decking
- White polyester powder coat finish over high zinc epoxy primer
- (3) Stabilizer jacks with a 750 lb capacity each. Capable of raising the trailer up to 8" from normal height
- 4.80 x 12 ST tires on 5 lug automotive type hubs, locking lugs included
- 2" Class II ball coupler
- Folding tongue caster jack
- Full 7" wide, 14 gauge steel fenders
- 2000 lb rated axle
- Leaf spring suspension
- Taper roller bearings
- Curb Weight: 900 lbs

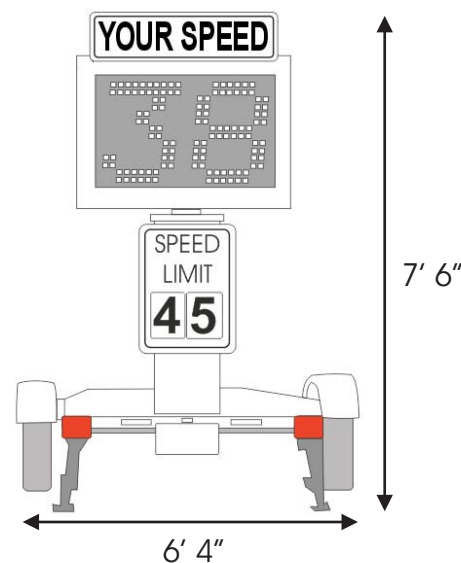
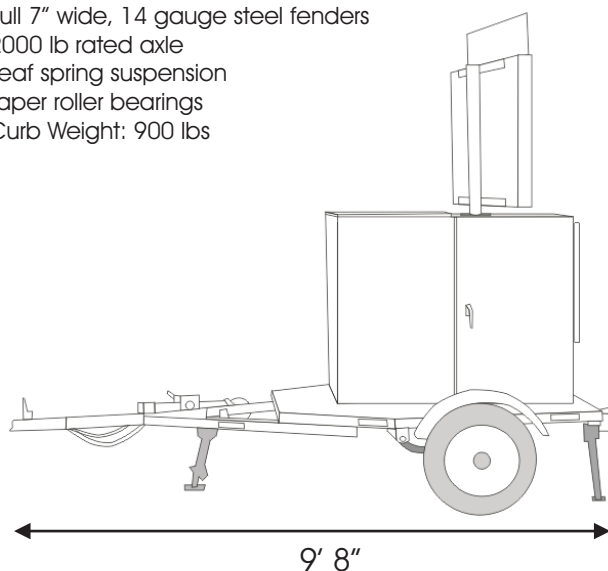
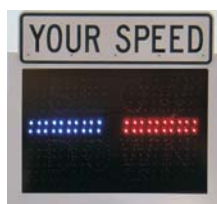

### WARRANTY:

RU2 Systems warrants their LED Displays and Trailers for Five Years. The Radar Gun is warranted for Two years. On-site labor is not included. However, parts are repaired within five business days of receipt, and include ground-shipping expenses. Warranty does not include physical damage from misuse or vandalism.

**RU2 Systems, Inc.**  
4840 E. Jasmine St., Suite 102  
Mesa, AZ 85205

[P] 480-982-2107 [F] 480-982-5237  
Toll Free 877-982-2107  
[www.ru2systems.com](http://www.ru2systems.com)